



Kasper Aero

# 1030AM101 Magnetic Debris Detector (MDD)

1/2" NPT 0-10V Output MS3102R14S-2P Connector

KasperAero Technical Data Sheet

## About the 1030 Product Family

The KasperAero 1030 Series is our ruggedized line of ferrous debris detection sensors, designed for demanding industrial, aerospace-adjacent, marine, and rail environments. Powered by our proprietary NZMS technology, the 1030 Series delivers industry-leading debris monitoring performance in a durable high-temperature platform.

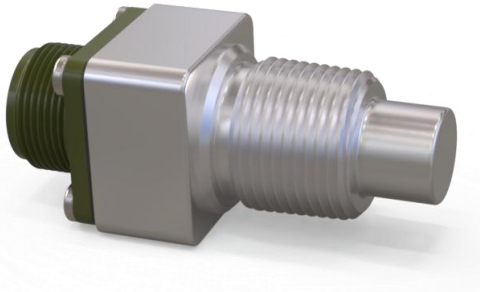

Entire Sensor  
(no separate electronics)

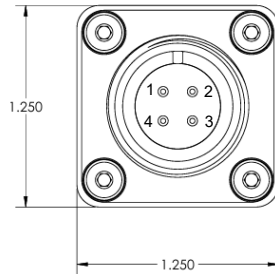

Electrical Data	
Pin 1, Power	11V – 26V
Pin 2, Analog Output	0.050V – 10.0V
Pin 2, Analog Output Resolution	0.010V
Pin 2, Analog Output Sensitivity	0.010 Volt / 0.010 Gram
Pin 3, Digital Output (< 0.050 grams of debris)	0V
Pin 3, Digital Output (> 0.050 grams of debris)	Supply Voltage
Pin 4, Ground	
Max Report Rate	[Hz] 10 Hz Max
Circuit Protection	
Reverse Polarity Protection	YES
Over Voltage Protection	YES
Short Circuit Protection	YES
Type of Short Circuit Protection	PULSED
Overload Protection	YES

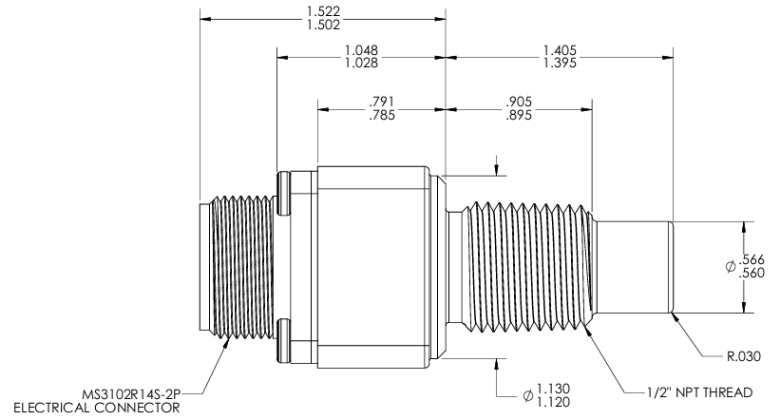

Mechanical	
Minimum Detectable Debris	0.010 grams of 10-micron Ferrous Debris (0.053 inch ball)
Maximum Detectable Debris	9.50 grams of 10-micron Ferrous Debris (0.520 inch ball)
Detectable Debris Media	Ferrous Only (Aluminum and Ceramic Debris Immune)
Sensor Body Material	6061-T6 Aluminum (Anodized)
Weight (LBS)	0.250 LBS Max
Environmental	
Sensor Protection	IP66 / IP68
Differential Pressure	400 psi (27.5 bar)
Maximum Operating Temperature	257°F (125°C)
Humidity	95% RH @ +135°F
Liquids	
Fuels	Gasoline, Diesel, Kerosene, Jet-A, JP-8, Avgas
Oils / Grease	Petroleum Oil, Grease, Mineral Oil, Synthetic Ester, Gear Oil, PAO based Oils, Automatic Transmission Fluid (ATF), Aeroshell Grease, Aero Lubriplate, Bunker Oil, Polyalkylene Glycol, Vegetable Oil
Hydraulics	Hydraulic Oils (HVI and ISO VG), Mineral Oil Based, Water-Glycol
Coolants	Ethylene Glycol, Propylene Glycol, Organic Acid Technology (OAT)
Other	Water, Salt Water, Methanol, Isopropyl Alcohol

Product not designed for ATEX environments. ATEX debris sensors must be custom solution.